

# SCALPER

2-WAY-SPLIT



## DIMENSIONS

### OPERATION:

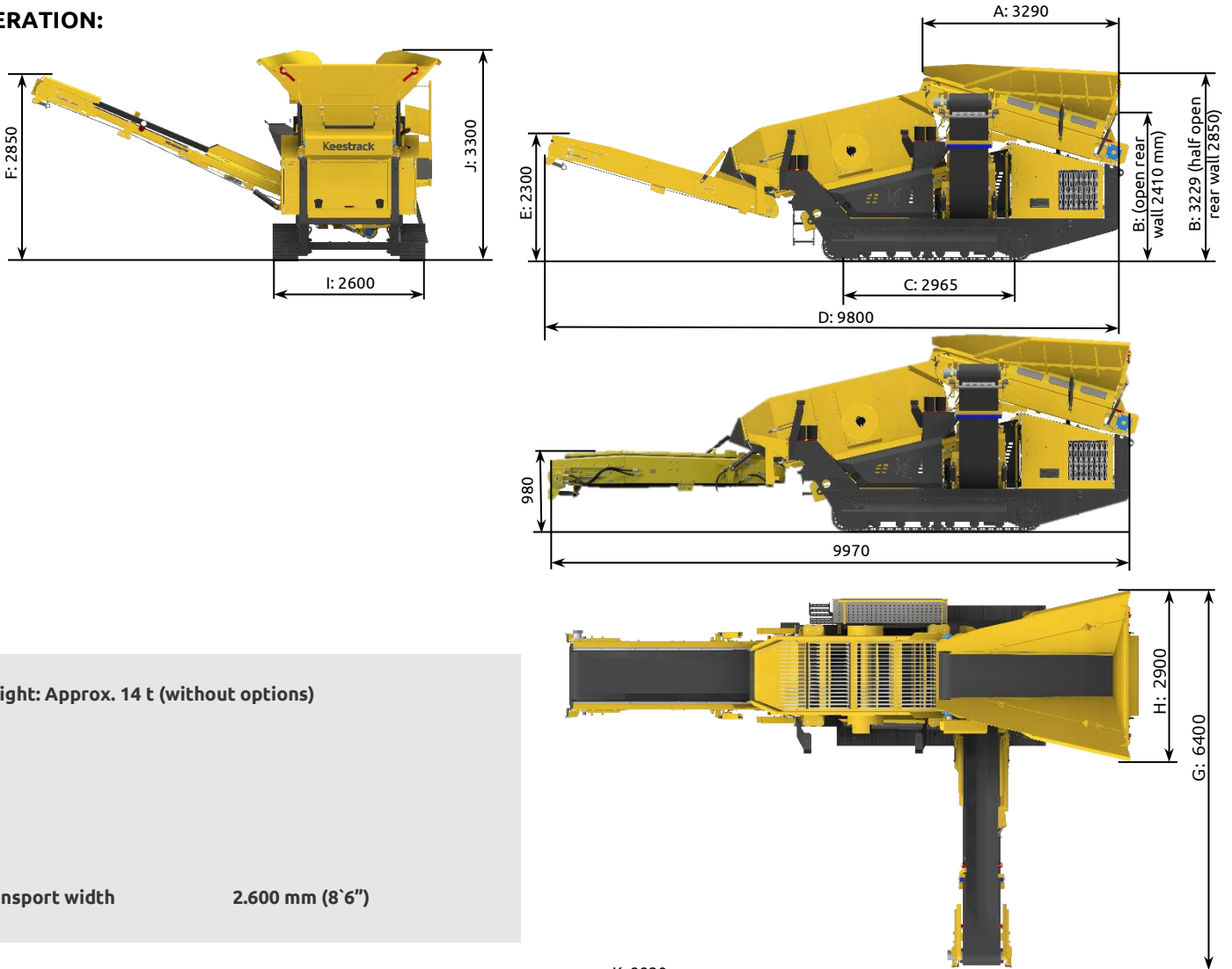

### TRANSPORT:

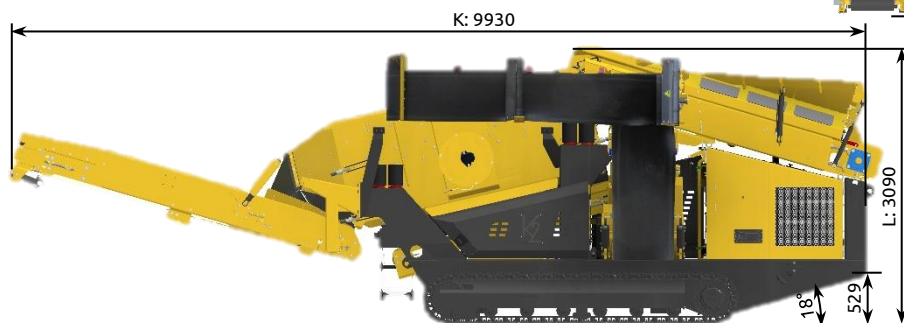

**REMARK:** All pictures might show options, not included in the scope of supply

A	B	C	D	E	F	G	H	I	J	K	L
3290	3229	2965	9800	2300	2850	6400	2900	2600	3300	9930	3090
10'10"	10'7"	9'9"	32'2"	7'7"	9'4"	21'0"	9'6"	8'6"	10'10"	32'7"	10'2"

## TECHNICAL SPECIFICATION

### 1) FEED HOPPER

- Model	33 MAS 100-00 (p/n 670800)	
- Content	3,5 m <sup>3</sup>	(4,6 yard <sup>3</sup> )
- Design	Wear resistant steel HB 355	
- Feeding height	Min. 2.410 mm	(7'11")
- Feeding width	2.820 mm	(9'3")
- Feeding length lateral	3.380 mm	(11'1")
- Hopper walls	All three hopper walls are folding hydraulic	

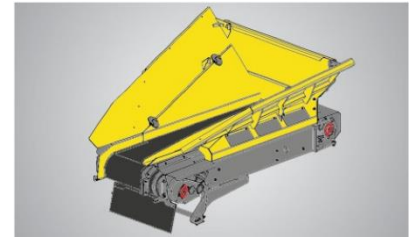

### 2) BELT FEEDER

- Model	31 BFR 100-00-K12 (p/n 612247) (for feeding fine material)	
- Full adjustable speed	0 - 4,8 m/min	(0-16 ft/min)
- Axle distance	3.083 mm	(10'4")
- Belt width	1.000 mm; EP 500/3 8+2 RIPSTOP	(3'3")
- Drive	Hydraulic with gearbox 5 kW	(7,5 hp)
- Feed capacity	200 t/h	

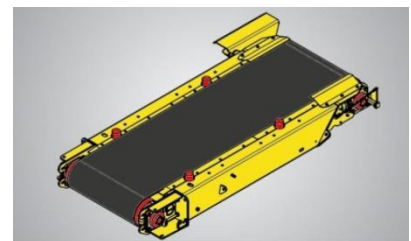

### 3) DOUBLE DECK SCREEN

- Model	31 SCR 200-00	
- Length x width	2.700 mm x 1.200 mm	(8'10" x 4'0")
- Effective screen area	Top deck 3,24 m <sup>2</sup> (protection deck only) Bottom deck 3,24 m <sup>2</sup>	
- Top deck screens	1 pcs. end tensioned	
- Bottom deck screens	2 pcs. end tensioned	
- Drive	Hydraulic 7,5 kW	(10,2 hp)

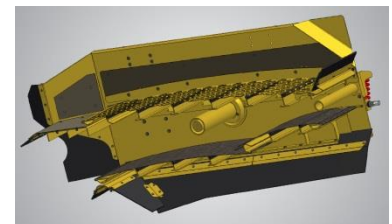

### 4) UNDERSCREEN CONVEYOR

- Model	31 USC 200-00	
- Length	3.000 mm	(9'10")
- Width	800 mm	(2'7")
- Drive	4 kW hydraulic motor	(5,5 hp)
- Rubber belt quality	EP 400/3 4+2 Grade N1	



### 5) OVERSIZE BELT CONVEYOR

- Length	3.700 mm	(12'2")
- Width	1.000 mm	(3'3")
- Drive	Hydraulic 5,5 kW	(7,5 hp)
- Rubber belt quality	EP 500/4 4+2	
Option:	(CHEVRON W = 750 mm H = 25 mm)	
- Positions	Hydraulic lower-able for changing bottom deck screens and for manual sorting of oversize fraction	
- Inclination	0 - 24 degrees	
- Stockpile volume	Approx. 40 t; $\gamma=1,7$ ; 37° angle of repose	

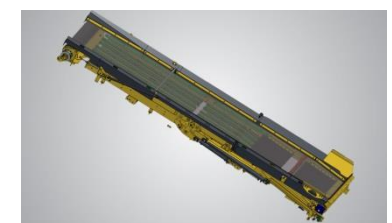

## TECHNICAL SPECIFICATION

### 6) STOCKPILE BELT CONVEYOR LEFT (FINE FRACTION)

- Length	5.530 mm	(18'2")
- Width	650 mm	(2'2")
- Drive	Hydraulic 7,5 kW	(11 hp)
- Inclination	24 degrees	
- Rubber belt quality	EP 315/3 4+2 Grade N17	
- Return drum	Lift time lubricated	
- Transport	Hydraulically fold-able	
- Operating positions	Can be built on the left and right side	
- Stockpile volume	Approx. 70 t ( $\gamma=1,7$ ; 37° angle of repose)	

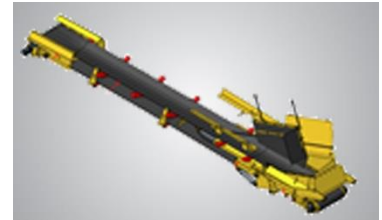

### 7) TRACK - UNIT

- Model	31 TRA-400-00	
- Length	2.965 mm	(9'9")
- Width track shoe	400 mm	(1'4")
- Total width	2.320 mm	(7'7")
- 2 speed	1,1 km/h and 1,9 km/h	(0,7/1,2 mph)
- Drive	Hydraulic piston motor and planetary gears	



### 8) ENGINE UNIT

- Model	31 ENU 300-00	
- Diesel engine type	DEUTZ TCD 2.9 L4; 4 cylinder in-line	p/n 101322
- Emission control	Tier 4i; EU STAGE IIIB; DOC (Option DPF p/n 101323)	
- Power acc. to ISO 14396	55,4 kW / 1.800 R.P.M.	(73 hp)
- Max. torque	300 Nm/1.600 R.P.M.	(221 lbft)
- Engine speed	1.800 R.P.M. Low engine speed for low fuel consumption	
- Bore / Stroke	92 / 110 mm	(3,7" x 4,4")
- Displacement	2.920 cm <sup>3</sup>	(178 cuin)
- Voltage	24 V (for improved cold start properties)	
- Battery	64035, 110 Ah-850 A	
- Electrical starter	2 kW; 24 V	
- Alternator	28 V; 55 A	
- Engine Operation	4-stroke Diesel direct injection turbo-charged	
- Cooling	water-cooled	
- Pushing Fan	550 diameter	
- Air Cleaner	dry type air-cleaner with cyclone pre-cleaner primary and safety elements	
- Fuel tank	284 litres	(75,5 gal)
- Fuel pre-filter	with water separator	
- Fuel code	according to EN 590	
- Consumption	215 g/kWh/2.000 R.P.M. (typical 6-8 l/h)	

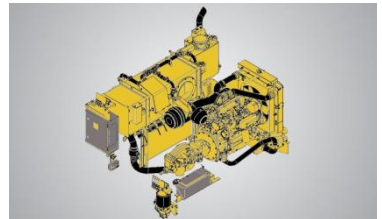

#### ATTENTION

*Engine warranty expires in case non genuine Keestrack filters are used!*



## TECHNICAL SPECIFICATION

### 9) HYDRAULIC

Hydraulic main pump	Variable flow, swash plate pump load sense open loop circuit 75 ccm	
Max. flow	135 + 40 + 25 = 200 L/min	(53 gpm)
Max. pressure	265 bar	
Pump regulation	servo hydraulic load sensing regulation, pressure compensation, automatic flow optimizer	
Hydraulic pump II	Fixed flow 22 ccm gear pump (for LSC)	
Hydraulic pump III	Fixed flow 14 ccm gear pump (for USC)	
Hydraulic tank	350 l	
Hydraulic oil filter	1 full flow filter in return line with integrated fine filter (10 µm)	(93 gal) (p/n 101187)
Hydraulic oil cooler	Integrated compact cooler, with water and air cooling package	
Hydraulic valves	PVG 32 proportional 5 bank valve	

**With „Load sensing” hydraulic pumps, the fuel consumption is reduced by Approx. 20-25%, compared to standard gear pump and flow divider hydraulic systems.**

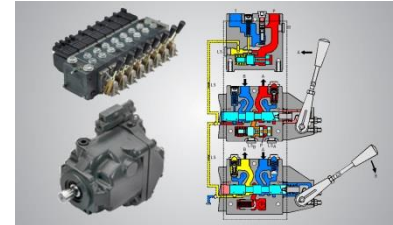

### 10) CONTROL

- Type	PLC – IP 67; dust and vibration proof
- Display	LCD screen 3,5”
- Operation	Control panel
- Controller	Wired hand remote controller; or optional Radio remote controller (see option list)
- Temperature control of hydraulic oil	> 83° C protection; first feeder stops, later engine stops
- Diesel fuel tank level sensor	First low level warning, then feeder stops, then engine stops
- Cold start protection	Below 0° C a warm-up is required
- Speed sensor for screenbox	Included





## TECHNICAL SPECIFICATION - OPTIONS

### 16) Options LSL and USC

#### TUNGSTEN SCRAPERS

- Application For wet and sticky material
- Available parts
  - p/n 102289: Tungsten scraper LSL + USC
  - p/n 101560: Tungsten scraper USC
  - p/n 101953: Tungsten scraper LSL



## TECHNICAL SPECIFICATION – SCREEN CHOICE

### 01) TOP DECK

#### PUNCHED PLATES

(feed size up to 400 mm)

p/n	Description
202382	TD CUTTED 40 mm - HB 450
202383	TD CUTTED 45 mm - HB 450
202384	TD CUTTED 50 mm - HB 450
202386	TD CUTTED 60 mm - HB 450
202387	TD CUTTED 65 mm - HB 450
202388	TD CUTTED 70 mm - HB 450
202390	TD CUTTED 80 mm - HB 450
202392	TD CUTTED 90 mm - HB 450
202380	TD CUTTED 100 mm - HB 450
202601	TD CUTTED 125 mm - HB 450
654933	TD CUTTED Front 125 mm – HB 450 Rear 150 mm - HB 450



#### WELDED WIRE MESH

p/n	Description
202296	TD WELDED 45 x 45 x 10 mm
202298	TD WELDED 55 x 55 x 12 mm
605234	TD WELDED 65 x 65 x 12 mm
202302	TD WELDED 80 x 80 x 12 mm



#### WOVEN WIRE MESH

p/n	Description
202228	TD MESH 16 x 16 x 3 mm
202175	TD MESH 20 x 20 x 4 mm
202417	TD MESH 25 x 25 x 5 mm
202418	TD MESH 30 x 30 x 5 mm
202093	TD MESH 35 x 35 x 7 mm
202245	TD MESH 40 x 40 x 5 mm
202247	TD MESH 50 x 50 x 8 mm
202246	TD MESH 45 x 45 x 8 mm
202248	TD MESH 55 x 55 x 9 mm
202250	TD MESH 60 x 60 x 9 mm
202252	TD MESH 70 x 70 x 9 mm
202254	TD MESH 80 x 80 x 12,5 mm





## TECHNICAL SPECIFICATION – SCREEN CHOICE

### 01) TOP DECK

#### FINGER SCREENS

Finger dimensions  $\varnothing 36 / \varnothing 17 \text{ mm} - 800 \text{ mm}$ ; p/n 101106

#### REMARK:

Finger openings average [mm]; forged fingers; deviations are possible; measuring of opening is in the beginning of the second third of the length of the finger.

p/n	mm	Inch
202497	45	1 3/4"
202498	52	2"
202499	60	2 1/3"



## TECHNICAL SPECIFICATION – SCREEN CHOICE

### 02) BOTTOM DECK

#### FINGER SCREENS With PU base

p/n	Description
612737	Fingers-segment $\varnothing$ 10/ s=15 mm
612738	Fingers-segment $\varnothing$ 12/ s=20 mm
612739	Fingers-segment $\varnothing$ 12/ s=27 mm
612740	Fingers-segment $\varnothing$ 15/ s=30 mm
202506	Bottom deck finger deck cassette frame



#### WOVEN WIRE MESH

p/n	Description
202055	BD MESH 2 x 2 x 1,25 mm
202227	BD MESH 3 x 3 x 2 mm
202425	BD MESH 4 x 4 x 2 mm
202231	BD MESH 6 x 6 x 2 mm
202180	BD MESH 8 x 8 x 2,5 mm
202137	BD MESH 10 x 10 x 3 mm
202225	BD MESH 12 x 12 x 3 mm
202996	BD MESH 15 x 15 x 3 mm
202341	BD MESH 16 x 16 x 3 mm
202522	BD MESH 18 x 18 x 4 mm
202998	BD MESH 20 x 20 x 4 mm
202528	BD MESH 22 x 22 x 4 mm
202997	BD MESH 25 x 25 x 5 mm
202157	BD MESH 30 x 30 x 5 mm
202131	BD MESH 35 x 35 x 7 mm
202995	BD MESH 40 x 40 x 8 mm
202449	BD MESH 45 x 45 x 8 mm
202143	BD MESH 50 x 50 x 8 mm
202256	BD MESH 55 x 55 x 10 mm
202058	BD MESH 60 x 60 x 8 mm
202647	BD MESH 70 x 70 x 10 mm

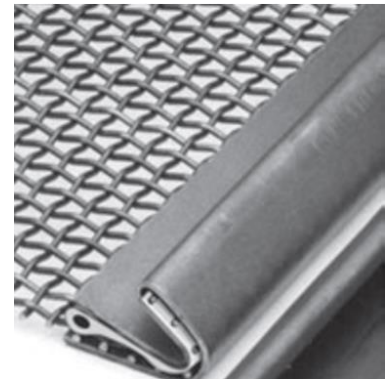
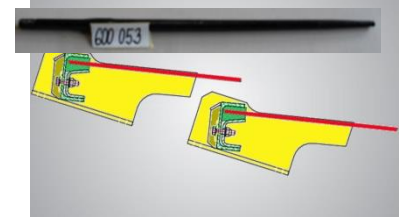

#### HARP SCREEN

Advantages:  
- high percentage of open screening area  
- less danger of clogging

p/n	Description
202404	BD HARP 3 x 200 x 1,2 mm
202405	BD HARP 4 x 200 x 1,2 mm
202191	BD HARP 6 x 200 x 2 mm
202158	BD HARP 8 x 200 x 2 mm
202336	BD HARP 10 x 100 x 2,5 mm
202188	BD HARP 10 x 200 x 2,5 mm
202179	BD HARP 12 x 200 x 2,5 mm
202150	BD HARP 15 x 200 x 3 mm
202473	BD HARP 18 x 100 x 3 mm
202545	BD HARP 20 x 100 x 4 mm
202207	BD HARP 20 x 200 x 4 mm
202209	BD HARP 25 x 200 x 4 mm
202210	BD HARP 30 x 200 x 5 mm



#### SERPA DIAMOND

202573	BD HARP- SERPA 6 x 200 x 2,5 mm
202264	BD HARP- SERPA 10 x 200 x 3 mm
202265	BD HARP- SERPA 12 x 200 x 3 mm
202266	BD HARP- SERPA 15 x 200 x 3 mm
202582	BD HARP- SERPA 16 x 120 x 3 mm

