

# CLASSIFIER

4-WAY-SPLIT

C6 (3 DECK)



# DIMENSIONS

## OPERATION:

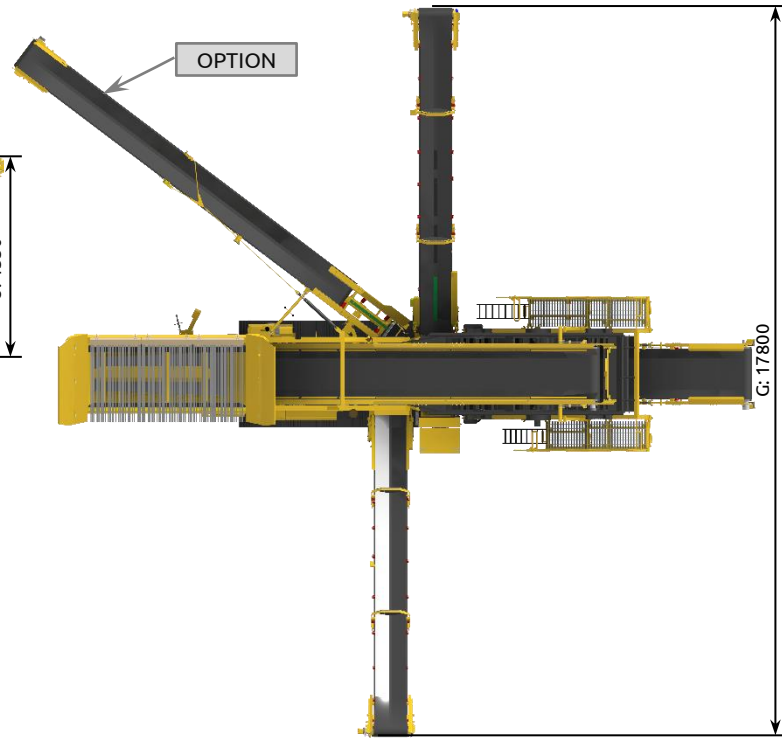
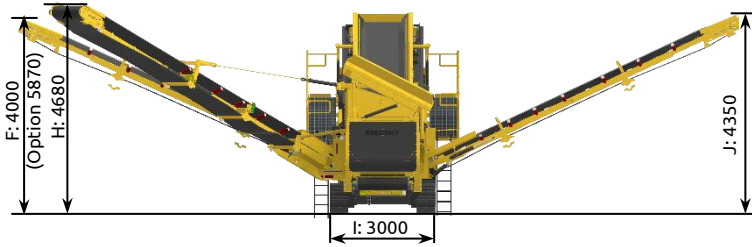
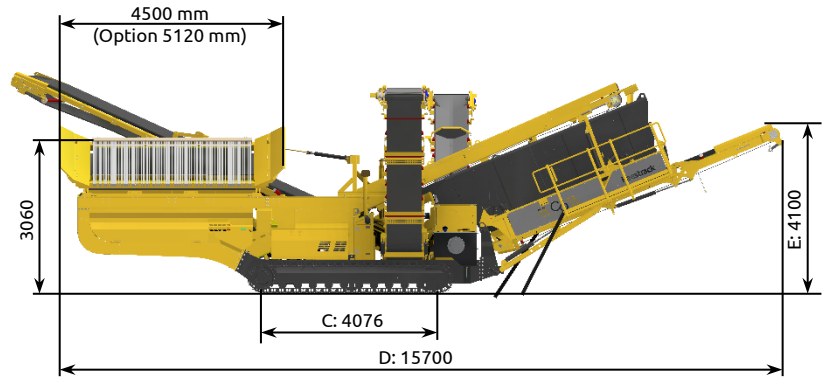
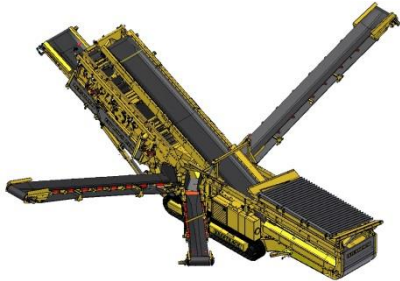

### Weight: approx. 31 t (without options)

- Weight options:
- Magnetic separator MCL 12 KT 8 + approx. 2.350 kg
  - Feeding width extension + approx. 60 kg
  - Wear lining hopper + approx. 230 kg
  - Conveyor LSB telescopic + approx. 150 kg

**Total weight with options approx. 33,8 t**

**Transport width 3.000 mm (9'10")**

## TRANSPORT:

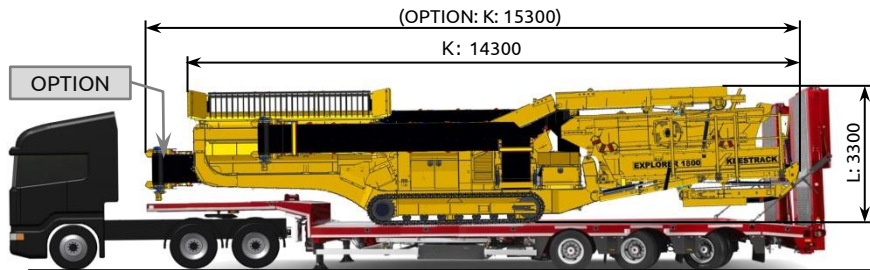

**REMARK:** All pictures might show options, not included in the scope of supply

A	B	C	D	E	F	G	H	I	J	K	L
4500	3060	4076	15700	4100	4000	17800	4680	3000	4350	14300	3300
14'9"	10'0"	13'4"	51'6"	13'5"	13'1"	58'5"	15'4"	9'10"	14'3"	46'11"	10'10"

## TECHNICAL SPECIFICATION

### 1) FEED HOPPER

- Content	8,1 m <sup>3</sup> ; with hopper extension 750 mm p/n 612700: 13 m <sup>3</sup>	(10 yard <sup>3</sup> )
- Design	Wear resistant steel HB 450	
- Feeding height	3.060 – 3.520 mm (without grid 2.400 mm)	(10'1" - 11'6")
- Feeding length lateral	4.500 mm	(14'9")
- Grid angle	Hydraulic adjustable 13, 14, 18, 24 and 28°	
- Grid opening	100 mm (p/n 661207) = Standard	(4")
	122 mm (p/n 661209)	(5")
	135 mm (p/n 661210)	(5,5")
	150 mm (p/n 661211)	(6")

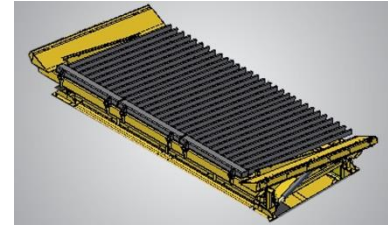

### 2) BELT FEEDER

- Model	60 BFR 102-00	
- Full adjustable speed	0 - 6,1 m/min	(0 - 20 ft/min)
- Axle distance	3.467 mm	(11'5")
- Belt width	1.200 mm	(3'11")
- Belt	EP 630/4 6+2 Grade Y	
- Drive	Hydraulic with gearbox 7,5 kW	(10,2 hp)
- Feed capacity	400 t/h	

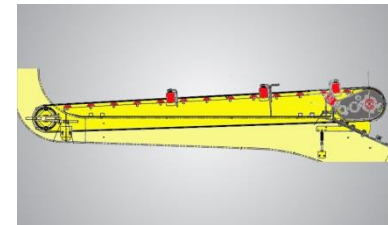

### 3) MAIN CONVEYOR

- Model	61 MCL 102-00	
- Length	9.440 mm	(31'0")
- Width	1.200 mm	(3'11")
- Drive	Hydraulic 15 kW	(20,4 hp)
- Rubber belt quality	EP 400/3 4+2 Grade N 17	

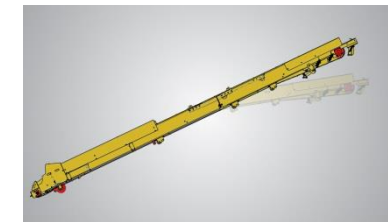

### 4) TRIPPLE DECK SCREEN

- Model	61 SCR 105-00	
- Length x width	4.500 mm x 1.800 mm	(14'9" x 5'11")
- Effective screen area	3 x 8,1 m <sup>2</sup>	
- Screens	a) Steel wire: Each deck 2 pcs. end tensioned b) OPTIONAL: screen deck made of Polyurethane with following fixation system: cross to the screen, square hollow sections are bolted to the screen sidewalls; C-profiles are screwed to the cross hollow sections; 30 mm high PU elements 300 x 1000 mm (total 4 m length) are inserted to the C-profiles; side liners, made of PU are fixed by wedges to hold the PU elements; p/n 202820: mesh 25 x 25 mm p/n: 202821 mesh 10 x 10 mm	
- Drive	Hydraulic 15 kW	(20 hp)
- Access walkway	On the left and right side; for transport hydraulically foldable; width 600 mm; with ladder on both sides	
- Screen inclination	Adjustable 9° - 24°	

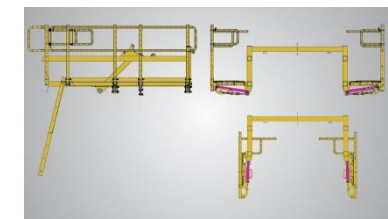
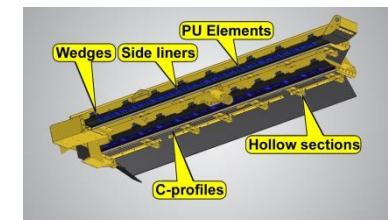
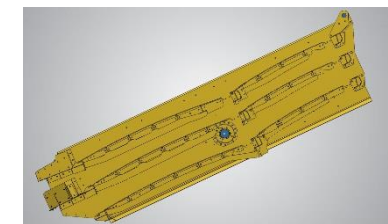



## TECHNICAL SPECIFICATION

### 5) UNDERSCREEN CONVEYOR (fine fraction)

- Model	60 USC 106-00-H	
- Length	6.750 mm	(22'2")
- Width	1.200 mm	(3'11")
- Drive	7,5 kW hydraulic motor	(11 hp)
- Rubber belt quality	EP 400/3 4+2	
- Transport	Hydraulically fold-able	
- Stockpile volume	approx. 160 t ( $\gamma=1,7$ ; 37° angle of repose)	

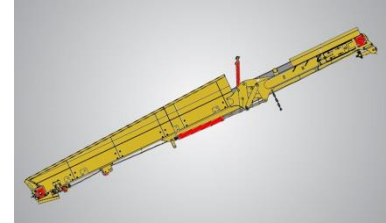

### 6) STOCKPILE BELT CONVEYOR LEFT (middle fraction)

- Model	60 LSL 106-00-H	
- Length	10.000 mm	(32'4")
- Width	800 mm	(2'8")
- Drive	Hydraulic 7,5 kW	(10,2 hp)
- Rubber belt quality	EP 400/3 3+1,5 V-385 Chevron 635/15	
- Transport	Hydraulically fold-able	
- Stockpile volume	approx. 320 t ( $\gamma=1,7$ ; 37° angle of repose)	



### 7) STOCKPILE CONVEYOR RIGHT (middle fraction coarse)

- Model	61 RSL 106-00-H	
- Length	10.000 mm	(32'4")
- Width	800 mm	(2'8")
- Drive	Hydraulic 7,5 kW	(10,2 hp)
- Rubber belt quality	EP 400/3 3+1,5 V-385 Chevron 635/15	
- Transport	Hydraulically fold-able	
- Stockpile volume	approx. 260 t ( $\gamma=1,7$ ; 37° angle of repose)	



### 8a) BELT CONVEYOR REVERSIBLE (coarse fraction)

- Model	61 OSR 100-00-H	
- Length	1.700 mm	(5'7")
- Width	650 mm	(2'2")
- Drive	Hydraulic 3 kW	(4 hp)
- Rubber belt quality	EP 250/2 3+1,5	
- Material discharge	Either to LSB or to RSL	

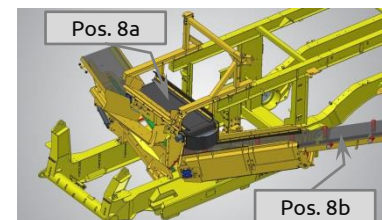

### 8b) STOCKPILE BELT CONVEYOR LEFT (coarse fraction)

- Model	61 LSB 300-00	
- Length	6.875 mm	(22'6")
- Width	650 mm	(2'2")
- Drive	Hydraulic 7,5 kW	(10,2 hp)
- Arrangement to frame	35 – 48 degrees; adjustable with spindle	
- Rubber belt quality	EP 400/3 3+1,5 V-385 Chevron Grade N16	
- Transport	Hydraulically fold-able	
- Stockpile volume	approx. 200 t. ( $\gamma=1,7$ ; 37° angle of repose)	



### 9) TRACK - UNIT

- Model	60 TRA-103-00	
- Length	4.076 mm	(13'4")
- Width track shoe	450 mm	(1'6")
- Total width	2.550 mm	(8'4")
- 2 speeds	1,32 km/h and 2,28 km/h	(0,8 / 1,5 mph)
- Drive	Hydraulic motor and planetary gears	



## TECHNICAL SPECIFICATION

### 10) ENGINE UNIT

- Model	60 ENU 105-00	
- Diesel engine type	a) DEUTZ TCD 3.6; L4 b) CATERPILLAR C 4.4 TA; fixed speed c) CATERPILLAR C 4.4	p/n 101449 p/n 103534 p/n 103084
- Emission control	a) Tier 4f; EU STAGE IV; DOC; SCR b) Tier 3; EU STAGE IIIA c) Tier 3; EU STAGE IIIA	<b>Latest technology</b>
- Power acc. to ISO 14396	a) 90 kW at 2.000 R.P.M. b) 85 kW at 1.500 R.P.M.; 98,1 kW at 1.800 R.P.M. c) 76 kW at 1.800 R.P.M.	(122 hp) (115/133 hp) (103 hp)
- Max. torque	a) 480 Nm / 1.600 R.P.M.; b) 546 Nm / 1.500 R.P.M. c) 404 Nm / 1.800 R.P.M.	(354 lb ft) (402 lb ft) (298 lb ft)
- Engine speed	1.800 R.P.M. Low engine speed for low fuel consumption	
- Bore / Stroke	a) 98 / 120 mm; b + c) 105 / 127 mm	(4,0" x 4,7")
- Displacement	a) 3.600 cm <sup>3</sup> ; b + c) 4.400 cm <sup>3</sup>	(219 – 269 cuin)
- Voltage	24 Volt (for improved cold start properties)	
- Battery	64035, 140 Ah-460 A	
- Electrical starter	24 Volt, 3 kW	
- Alternator	26 Volt, 55 A	
- Engine Operation	4-stroke Diesel direct injection turbo-charged	
- Cooling	water-cooled	
- Pushing Fan	550 diameter	
- Air Cleaner	dry type air-cleaner with syclone pre-cleaner primary and safety elements	
- Fuel tank	245 litres	(65 gal)
- Fuel pre-filter	with water separator	
- Fuel code	according to DIN 51601	
- Consumption	a) 232 g/kWh/1800 rpm (typical 11 – 13 l/h)	

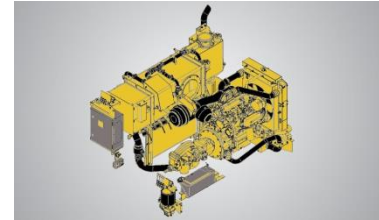

### ATTENTION

*Engine warranty expires in case non genuine  
Keestrack filters are used!*

## TECHNICAL SPECIFICATION

### 11) HYDRAULIC

Hydraulic main pump	Variable flow, swash plate pump load sense open loop circuit 100 cc	
Max. flow	180 + 68 + 40 = 288 l/min at 1800 R.P.M.	(75 gpm)
Max. pressure	265 bar	(3.770 psi)
Pump regulation	servo hydraulic load sensing regulation, pressure compensation, flow compensation automatic flow optimizer	
Hydraulic pump II	Fixed flow 38 cc gear pump (for LSB)	
Hydraulic pump III	Fixed flow 22 cc gear pump (for USC)	
Hydraulic tank	400 l	(123 gal)
Hydraulic oil filter	1 full flow filter in return line with integrated fine filter area (10 µm)	
Hydraulic oil cooler	Integrated compact cooler, with water and air cooling package	
Hydraulic valves	PVG 32 proportional 6 bank valve <b>With „Load sensing” hydraulic pumps, the fuel consumption is reduced by approx. 20-25%, compared to standard hydraulic systems.</b>	

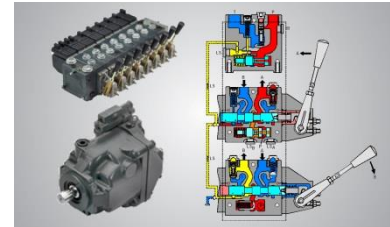

### 12) CONTROL

- Type	PLC – IP 67; dust and vibration proof	p/n 103485
- Display	LCD screen 4,3”	
- Operation	Control panel	
- Controller	Wired hand remote controller; or optional Radio remote controller (see option list)	
- Temperature control of hydraulic oil	> 83° C protection; first feeder stops, later engine stops	
- Diesel fuel tank level sensor	First low level warning, then feeder stops, then engine stops	
- Cold start protection	Below 0° C a warm-up is required	
- Speed sensor for screen box	Included	



## TECHNICAL SPECIFICATION - OPTIONS

### 13) MAGNETIC SEPARATOR MCL p/n X115492 - 12 KT-FE 80-198

- Type	12 KT-FE 80-198 for MCL	
- Length	1.980 mm	(6'6")
- Width	850 mm	(2'7")
- Magnetic power	420 GAUSS at 250 mm distance	
- Magnet dimensions	1.170 x 750 mm	(3'10" x 2'6")
- Speed	2,5 m/s	
- Drive	Hydraulic motor 5,5 kW	(7,5 hp)
- Weight	2.050 kg	(2.300 lb)
- Frame for Magnet MCL	p/n 661097; 294 kg (including discharge chute MCL p/n 661150 – 54 kg)	(650 lb)
- Magnet drum RSL with Discharge chute	p/n 661695; chute 3 m; 1000 mm; for transport disassembled; 112 kg;	(235 lb)

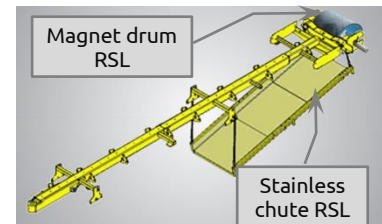
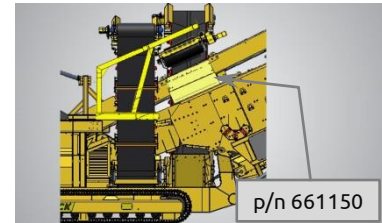

### 14) RADIO REMOTE CONTROL – Level 2

- Order no.	Remote 103162 Sticker 101471
- Functions	<ul style="list-style-type: none"> <li>- Tracks forwards / backwards with automatic speed control</li> <li>- Tilting grid up / down</li> <li>- Belt feeder start / stop and + / -</li> <li>- Automatic start / stop</li> <li>- RSL start / stop and + / -</li> <li>- Machine stop button (blue)</li> <li>- Display</li> </ul>



### 15) WORKING LIGHTS

- Tower with 4 lamps	p/n 701006 LED lights 12/24 V; 45 W each lamp: 9 pcs. LED's (p/n 205147) 4500 Lumen	
- protection degree	IP69K	
- Weight	9 kg	(20 lb)

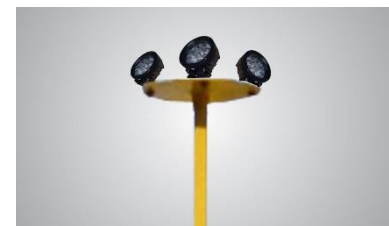

### 16) FUEL FILLING PUMP p/n 701030

- with automatic stop	p/n 701030	
- Weight	10 kg	(22 lb)
- Model	F 80-24-1"	
- Capacity	80 l/min	
- Filter	3 micron with water absorbent media	
- Suction hose	¾" 1,5 m long	
- Drive	On board-electric 24 V DC	



## TECHNICAL SPECIFICATION - OPTIONS

### 17) ANTI CLOGGING SYSTEM p/n 102499

- Application To be used for bottom deck if the feed material is sticky and the deck is clogging
- Weight 30 kg (per deck) (65 lb)



### 18) 2<sup>nd</sup> LEVEL WALKWAY ALONG THE SCREEN p/n 640902

- Arranged On the left and right side of the screen, above the standard walkway, which is hydraulically fold-able for transport
- Application For cleaning the upper deck of the screen
- Weight 61 kg (130 lb)

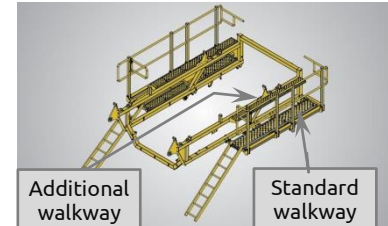

### 19) Options MCL and USC

#### TUNGSTEN SCRAPERS

- Application For wet and sticky material
- Available parts p/n 760002: Tungsten scraper MCL + USC

#### BELT COVER

- Fixation for MCL and USC; p/n 760005 with expander belt
- Weight 90 kg (190 lb)



### 20) Options to STANDARD HOPPER

- HOPPER EXTENSIONS** H=750 mm; p/n 612700
- Weight approx. + 550 kg (+1.200 lb)
  - Hopper volume 13 m<sup>3</sup> (16 yard<sup>3</sup>)

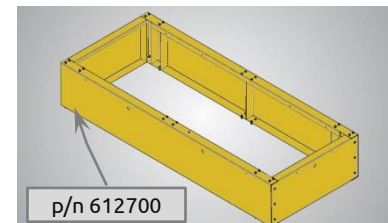

- FEEDING WIDTH EXTENSIONS** On the right and left side of the hopper p/n 661206; + 60 kg (+ 130 lb)
- Feeding width 5.120 mm (16'10")

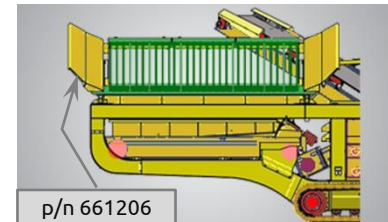

- WEAR LINING HOPPER** Wear lining HB 450; s=8 mm p/n 662500; + 230 kg (+ 490 lb)



## TECHNICAL SPECIFICATION - OPTIONS

### 21) DRIVEN VIBRATING GRID, SINGLE DECK (above hopper)

- Inclination	Hydraulically adjustable 10, 12, 14, 16°	
- Feeding height	3.275 - 3.455 mm acc. to inclination	(10'9" - 11'4")
- Feeding width	4.050 mm	(13'3")
<b>Model with grizzly</b>	60 VBF 100-00; p/n 662520	
- Screens	Opening conical: 50/80 mm; p/n 663527	(3")
	Opening conical: 70/100 mm; p/n 662524	(4")
<b>Model with Screen</b>	60 VBF 100-01-00 K12; p/n 662621	
- Length x width	1.730 mm x 2.970 mm	(5'8" x 9'9")
- Effective screen area	5,1 m <sup>2</sup>	
- Screens	a) Punched plates hexagonal: 2 pcs. end tensioned; HB 450	
	Opening 85 mm: p/n 662373	(3 1/3")
	Opening 100 mm: p/n 662459	(4")
	Opening 120 mm: p/n 203987	(5")
	Opening 150 mm: p/n 695945	(6")
	b) Wire mesh in various openings	
- Drive	Hydraulic 11 kW	(15 hp)
- Weight	+ approx. 1.500 kg	(+ 3.150 lb)



With grizzly



With screen

### 22) DRIVEN VIBRATING GRID, DOUBLE DECK (above hopper)

- Type	60 GVI 200-00; p/n 660640	
- Inclination	Hydraulically adjustable 0, 5, 10, 15, 20°	
- Feeding height	3.180 - 3.692 mm acc. to inclination	(9'9" - 12'1")
- Feeding width	3.578 mm	(11'9")
- Upper deck with grizzly	Opening: 80 mm; p/n 641254	
	Opening conical: 90/120 mm; p/n 661385	(3")
- Lower deck screen	40 - 100 mm	(1,5" - 4")
- Length x width	2.180 mm x 3.600 mm	(7'2" x 11'10")
- Effective screen area	5,1 m <sup>2</sup>	
- Screens	a) Welded wire mesh: 2 pcs. tensioned longitudinally; HB 450	
	Opening 40 x 40 x 10 mm: p/n 640808	(1 1/2")
	Opening 70 x 70 x 10 mm: p/n 640880	(2 3/4")
	Opening 80 x 80 x 12 mm: p/n 202653	(3 1/4")
	Opening 100 x 100 x 12 mm: p/n 661645	(4")
	b) Wire mesh in various openings p/n662750	
- Drive	Hydraulic 11 kW	(15 hp)
- Weight	+ approx. 2.200 kg	(+ 4.620 lb)

Upper deck grizzly

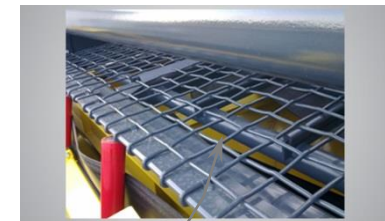

Lower deck screen

### 23) BELT FEEDER (low infeed conveyor)

- Type	800 x 13.500 mm; p/n 663100
- Belt	1EP 400/3 4+2
- Transport	Hydraulically foldable

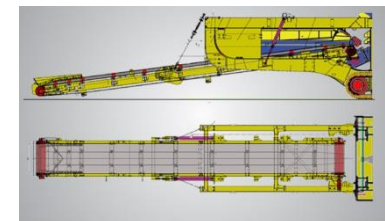

### 24) WITHOUT TIPPING GRID p/n 701003

- Application	For direct feed from pre-arranged plant
---------------	---



## TECHNICAL SPECIFICATION - OPTIONS

### 25) SHREDDER AFTER BELT FEEDER p/n 740002

- Application For release of clogging lumps in the feed material (topsoil)



### 26) TELESCOPIC CONVEYOR for coarse fraction p/n 662720

- Model 61 LSB 101-01-00
- Length 11.600 mm (38'0")
- Width 650 mm (2'2")
- Drive Hydraulic 11 kW (15 hp)
- Rubber belt quality EP 400/3 4+2 V-440 Chevron Grade N17
- Transport Hydraulically fold-able and hydraulically telescoped
- Telescoping procedure Insert pin, extend hydraulically, remove pin, cylinder back a.s.o.
- Stockpile volume approx. 630 t ( $\gamma=1,7$ ; 37° angle of repose)
- Weight + 150 kg (+320 lb)

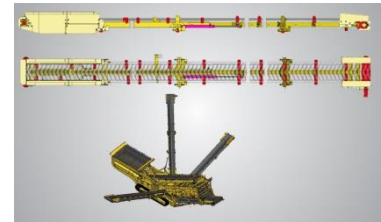

### 27) Options for HYDRAULIC, ENGINE UNIT and CONTROL

**HEATER ON FUEL PRE-FILTER WITH WATER SEPARATOR 7 micron** 24 V: p/n 101274  
12 V: p/n 101270

**HEATING SYSTEM FOR ENGINE** p/n 203460

- Heating power Up to 9,1 kW;
- Fuel consumption 0,19 - 1,1 l/h
- Voltage / Watt 24V; 37 - 90 W
- Operating temperature -40°C - + 80°C
- Weight 4,8 kg
- Additional Incl. timer for 3 starting times and temperature pre-selection

**EXTENDED HYDRAULIC PUMP** 130 ccm (instead of 100 ccm); p/n 101822;

**POWERCORE AIR PRE FILTER** For extremely dusty surroundings; p/n 102669

**DEUTZ ENGINE BF 4 M 2012 Tier 2 (EU STAGE II)** p/n 102325

**ENGINE COLD START (pre-heating) (for DEUTZ BF 4 M 2012 only)** p/n 102324

**TROPICAL THERMOSTAT (for DEUTZ BF 4 M 2012 only)** p/n 105180



HEATING SYSTEM FOR ENGINE



POWERCORE AIR PRE-FILTER

## TECHNICAL SPECIFICATION – OPTIONS

### 28) UMTS MODEM WITH GPS TRACKING SYSTEM “KEESTRACKER” (without SIM card) p/n 102971

- Functions
- WEB portal: position of the machine can be displayed on Google Maps; a geo-fence can be generated.

**FOR DEALER ONLY:**

- Real time access to Diesel engine, parameters of components and alarms.

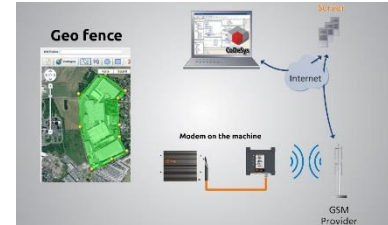

### TRANSFER MACHINE DATA THROUGH KEESTRACKER

The Buyer will not transfer personal data to KEESTRACK. As part of the service, KEESTRACK will receive the following data regarding the machine through "Keestracker", the tracking and controlling system of the machine in question:

- Location data of the machine
- Machine usage data (such as: performance of the engine and other functions)

The Buyer acknowledges that this information does not constitute confidential business information of the Buyer. The Buyer provides its explicit consent for this data collection and takes appropriate technical and organizational measures to ensure that natural persons cannot be identified by these mechanical data.

The Buyer explicitly acknowledges that this information is provided free of charge to KEESTRACK for the delivery of services offered by KEESTRACK and to adapt or improve its services and/or products.

## TECHNICAL SPECIFICATION – OPTIONS

### 29) WASHING SCREEN (without USC) p/n 641270

- Model	61 SCR 200-00	
- length x width	4500 mm x 1800 mm	(14'9" x 5'11")
- Effective screen area	3 x 8,1 m <sup>2</sup>	
- Deck mesh	3 pcs. tensioned lengthwise each	
- Drive	Hydraulic 15 kW	
- Water lines	Top deck 5, middle deck 4, bottom deck 4 lines; each line 2" can be closed with ball valve	
- Nozzles	72 pcs.; water consumption each 40 l/min	
- Water consumption	Totally 170 m <sup>3</sup> /h at min. 2 bar at the flange; water pump not KEESTRACK's scope of supply	
- Water connection	Flange 6" acc. to DIN 2576	
- Suspension discharge	to square discharge pan 224 x 365 mm; rubber coated (p/n 679055)	(9" x 1'2")

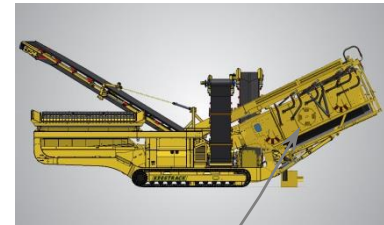

Washing screen

Water supply flange 6"



Square suspension discharge



discharge pan (p/n 679055)

72 pcs. nozzles

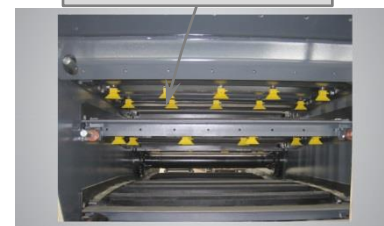

### 30) CENTRAL GREASING SYSTEM p/n 102908

- Cycle time	Adjustable	
- Drive	On board electric, 24 V DC	
- Weight	6 kg	(13 lb)





## TECHNICAL SPECIFICATION – SCREEN CHOICE

### 01) TOP, MIDDLE AND BOTTOM DECK

#### WOVEN WIRE MESH

Spi 2610 + 1810 mm

Spl 1760 mm

p/n	Description
202401	BD MESH 4 x 4 x 1,5 mm
202334	BD MESH 5 x 5 x 2 mm
202226	BD MESH 6 x 6 x 2 mm
202591	BD MESH 7 x 7 x 2 mm
202044	BD MESH 8 x 8 x 2,5 mm (stainless 202607)
202045	BD MESH 10 x 10 x 2,5 mm
202046	BD MESH 12 x 12 x 3 mm
202048	BD MESH 14 x 14 x 2,5 mm
202047	BD MESH 15 x 15 x 3 mm
202085	BD MESH 16 x 16 x 3 mm
202581	BD MESH 17 x 17 x 3 mm
202205	BD MESH 18 x 18 x 4 mm
202048	BD MESH 20 x 20 x 4 mm
202551	BD MESH 20 x 20 x 5 mm
202220	BD MESH 22 x 22 x 4 mm
202060	BD MESH 24 x 24 x 5 mm
202049	BD MESH 25 x 25 x 5 mm
202203	BD MESH 28 x 28 x 5 mm
202050	BD MESH 30 x 30 x 5 mm
202469	BD MESH 32 x 32 x 6 mm
202204	BD MESH 35 x 35 x 7 mm
202051	BD MESH 40 x 40 x 8 mm
202104	BD MESH 45 x 45 x 8 mm
202052	BD MESH 50 x 50 x 8 mm
202257	BD MESH 55 x 55 x 10 mm
202176	BD MESH 60 x 60 x 10 mm
202394	BD MESH 70 x 70 x 10 mm
202395	BD MESH 75 x 75 x 12,5 mm
202053	BD MESH 80 x 80 x 12,5 mm



#### HARP SCREEN

Advantages:

- high percentage of open screening area
- less danger of clogging

p/n	Description
202208	BD HARP 3 x 200 x 1,2 mm
202672	BD HARP 4 x 100 x 2 mm
202031	BD HARP 4 x 200 x 2 mm
202181	BD HARP 5 x 100 x 1,6 mm
202032	BD HARP 5 x 200 x 2 mm
202391	BD HARP 6 x 40 x 2 mm
202426	BD HARP 6 x 150 x 3 mm
202033	BD HARP 6 x 200 x 2 mm
202537	BD HARP 8 x 50 x 2,5 mm
202034	BD HARP 8 x 200 x 2 mm
202416	BD HARP 10 x 50 x 2 mm
202035	BD HARP 10 x 200 x 2,8 mm
202036	BD HARP 12 x 200 x 3 mm
202219	BD HARP 15 x 40 x 2 mm
202613	BD HARP 15 x 150 x 4 mm
202037	BD HARP 15 x 200 x 3 mm
202427	BD HARP 16 x 50 x 3 mm
202099	BD HARP 20 x 200 x 4 mm
202039	BD HARP 25 x 200 x 4 mm
202040	BD HARP 30 x 200 x 5 mm
202041	BD HARP 40 x 200 x 5 mm



#### SERPA DIAMOND

202698	BD HARP-SERPA 6 x 200 x 2,5 mm
202259	BD HARP-SERPA 12 x 200 x 3 mm
202136	BD HARP-SERPA 15 x 200 x 3 mm
202834	BD HARP-SERPA 25 x 200 x 3 mm

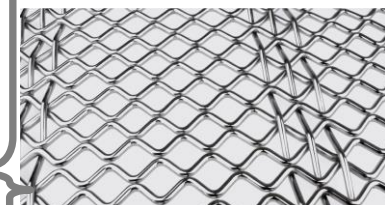

#### S-WAVE SCREEN MESH

202258	BD S-WAVE 10 x 200 x 2,5 mm
--------	-----------------------------

